



SO TOUGH,
WE GUARANTEE IT.



SBH / SBV Sales Guide

BLOWER-COILS HORIZONTAL AND VERTICAL

/// SBH

/// SBV



SBH / SBV Series: CONSTRUCTION FEATURES

Model SBH

Hanger holes in top and bottom panels for thru-rod installation

18-gauge, galvanized-steel casing capable of withstanding 125-hour, salt-spray test per ASTM B-117

Product label including tagging, airflow and electrical information

Pipe stubouts extend through unit casing

ETL label

Access panels on both sides for easy access to blower and motor

NEMA 1 control enclosure

Forward-curved fan



Model SBV

Multi-bend construction for optimum strength and rigidity

1" duct collar allows for quick field-connection of duct work

Control enclosure houses optional starter, disconnect, fusing and more

Filter rack allows for 2" filter

Full-size access panels

Cooling-coil panels have oversized holes with pipe insulation extended to coil header

4 or 6-row cooling coil with 1 or 2-row heating coil in preheat or reheat



SBH / SBV Series: THE BEST IN HORIZONTAL AND VERTICAL BELT-DRIVE DESIGNS

Owners

An extensive variety of components provide a flexible and versatile blower-coil unit to meet the needs of your building. Plus, the variety of options available with SBH and SBV units is where you find the versatility to fit any Heating, Ventilating, and Air-Conditioning (HVAC) need for your facility.

Options include:

- » Mixing boxes with low-leak dampers
- » High-efficiency filter sections for 2" pre-filter and 4" final filter
- » Blow-through electric heat with or without a single-point power connection

Designers

SBH horizontal and SBV vertical units are designed to maximize selection flexibility and installation, making them versatile enough to fit any HVAC design need. And the units are designed to exceed the stringent quality standards of the institutional market, while remaining cost-competitive in the light-commercial segment. AHJ and AVI blower-coil units set the new standard for quality, flexibility, and competitive pricing.

Contractors

Units are shipped completely assembled, reducing field-installation time and labor. High-efficiency motors, starters, disconnects, and fusing mean easier coordination between the mechanical and electrical trades.

All units, with or without electric heat, are cETL listed and labeled. All wiring is in compliance with NEC, ensuring safety and quality for the owner.



Model SBV, with standard filter rack

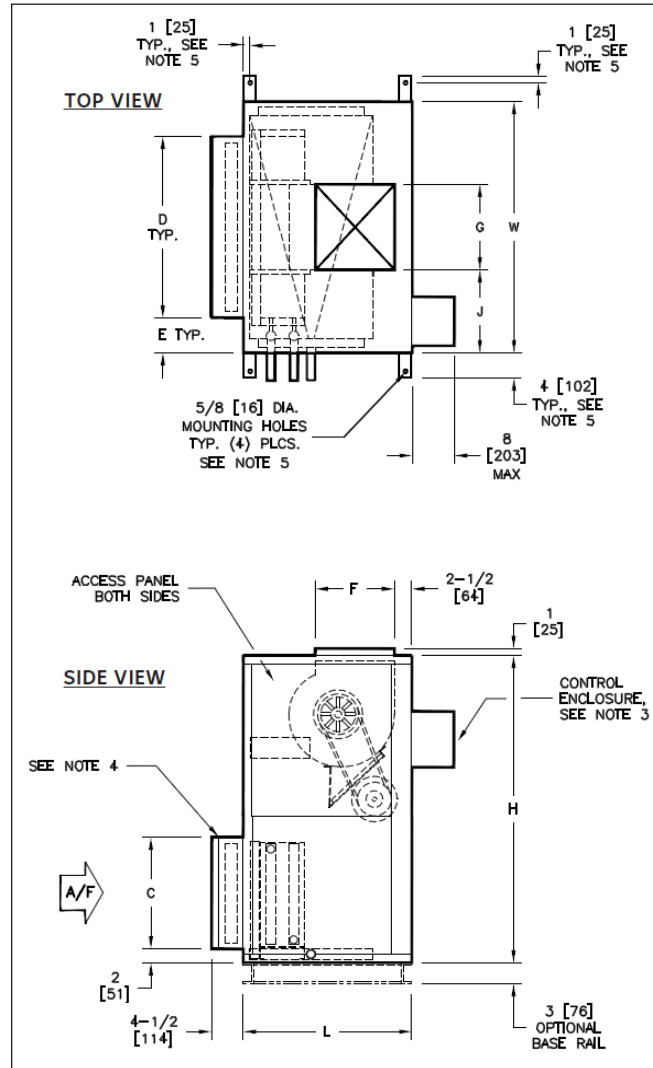

Unit Size	Dimensions									
	Fan Size	L	W	H	C	D	E	F	G	J
08	9" x 4" [229 x 102]	24" [610]	30" [762]	44" [1118]	16" [406]	20" [508]	5" [127]	10 1/4" [260]	6 7/8" [175]	11 9/16" [294]
12	9" x 6" [229 x 152]	24" [610]	36" [914]	44" [1118]	16" [406]	25" [635]	5 1/2" [140]	11 1/4" [286]	8 1/4" [210]	13 7/8" [352]
16	10" x 8" [254 x 203]	24" [610]	44" [1118]	44" [1118]	16" [406]	39 1/2" [1003]	2 1/4" [57]	13 1/2" [343]	10 1/4" [238]	16 7/8" [429]
20	10" x 10" [254 x 254]	30" [762]	50" [1270]	50" [1270]	16" [406]	44 1/2" [1130]	2 3/4" [70]	13 1/2" [343]	13 3/4" [337]	18 3/8" [467]
30	15" x 9" [381 x 229]	30" [762]	59" [1499]	56" [1422]	25" [635]	51" [1295]	4" [102]	16" [406]	13 3/4" [337]	22 7/8" [581]
40	15" x 11" [381 x 279]	30" [762]	68" [1727]	59" [1499]	25" [635]	59" [1499]	4 1/2" [114]	16" [406]	15" [381]	26 1/2" [673]

Model SBH, with standard filter rack

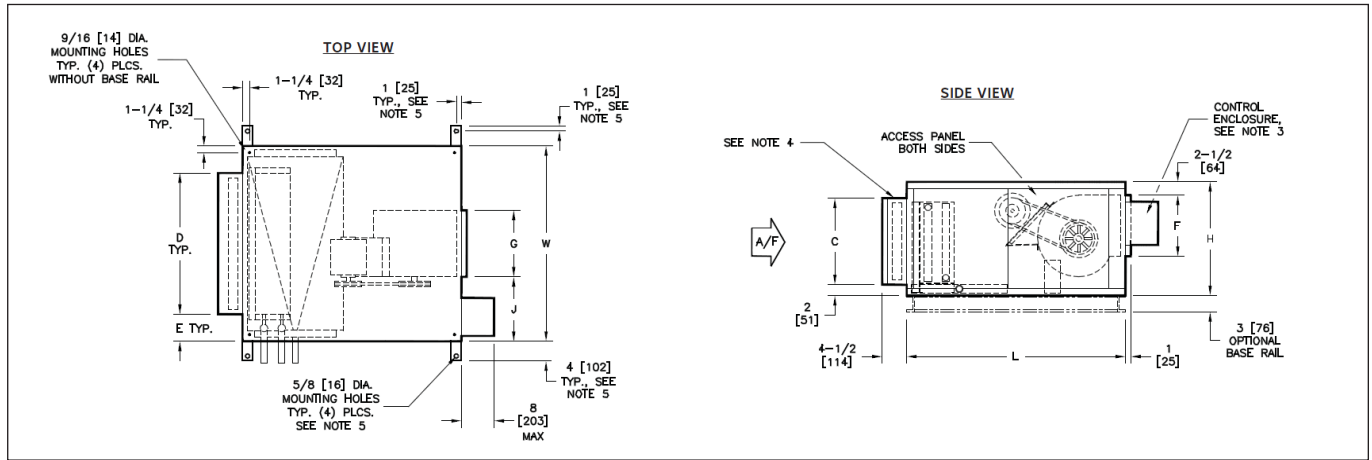

Unit Size	Dimensions									
	Fan Size	L	W	H	C	D	E	F	G	J
08	9" x 4" [229 x 102]	40" [1016]	30" [762]	21" [533]	16" [406]	20" [508]	5" [127]	10 1/4" [260]	6 7/8" [175]	11 9/16" [294]
12	9" x 6" [229 x 152]	40" [1016]	36" [914]	21" [533]	16" [406]	25" [635]	5 1/2" [140]	11 1/4" [286]	8 1/4" [210]	13 7/8" [352]
16	10" x 8" [254 x 203]	40" [1016]	44" [1118]	21" [533]	16" [406]	39 1/2" [1003]	2 1/4" [57]	11 3/8" [289]	10 1/4" [238]	16 7/8" [429]
20	10" x 10" [254 x 254]	40" [1016]	50" [1270]	21" [533]	16" [406]	44 1/2" [1130]	2 3/4" [70]	11 3/8" [289]	13 3/4" [337]	18 5/8" [467]
30	15" x 9" [381 x 229]	46" [1168]	59" [1499]	30" [762]	25" [635]	51" [1295]	4" [102]	16" [406]	13 3/4" [337]	22 7/8" [581]
40	15" x 11" [381 x 279]	46" [1168]	68" [1727]	30" [762]	25" [635]	59" [1499]	4 1/2" [114]	16" [406]	15" [381]	26 1/2" [673]

Model SBH/SBV, Blow-Thru Electric Heat

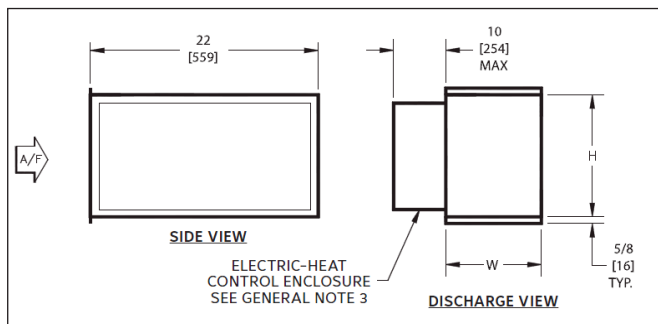

Unit Size	Dimensions		
	H	W	Weight in lbs [kg]
08	11 7/8" [302]	8 7/8" [225]	42 [19]
12	11 7/8" [302]	8 7/8" [225]	42 [19]
16	12" [305]	10 7/8" [275]	42 [19]
20	12" [305]	13 7/8" [352]	50 [23]
30	16 5/8" [422]	13 7/8" [352]	55 [25]
40	16 5/8" [422]	15 9/8" [397]	55 [25]

Model SBH/SBV, Standard Flat-Filter Rack

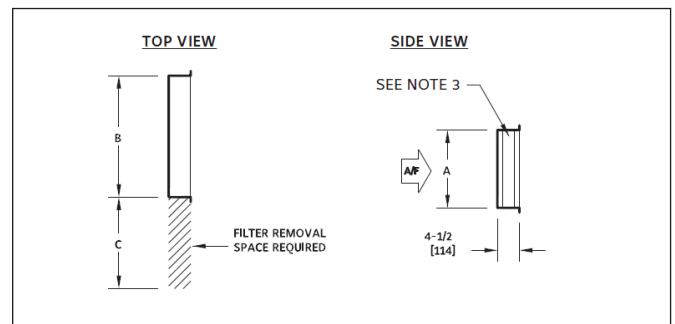

Unit Size	Dimensions			
	A	B	C	(Qty) & Size Filters
08	16" [406]	20" [508]	20" [508]	(1) 16" x 20"
12	16" [406]	25" [635]	25" [635]	(1) 16" x 25"
16	16" [406]	39 1/2" [1003]	20" [508]	(2) 16" x 20"
20	16" [406]	44 1/2" [1130]	25" [635]	(1) 16" x 20" (1) 16" x 25"
30	25" [635]	51" [1295]	25" [635]	(2) 16" x 25" (1) 20" x 25"
40	25" [635]	59" [1499]	25" [635]	(3) 20" x 25"

Model SBH/SBV, Standard Mixing Box

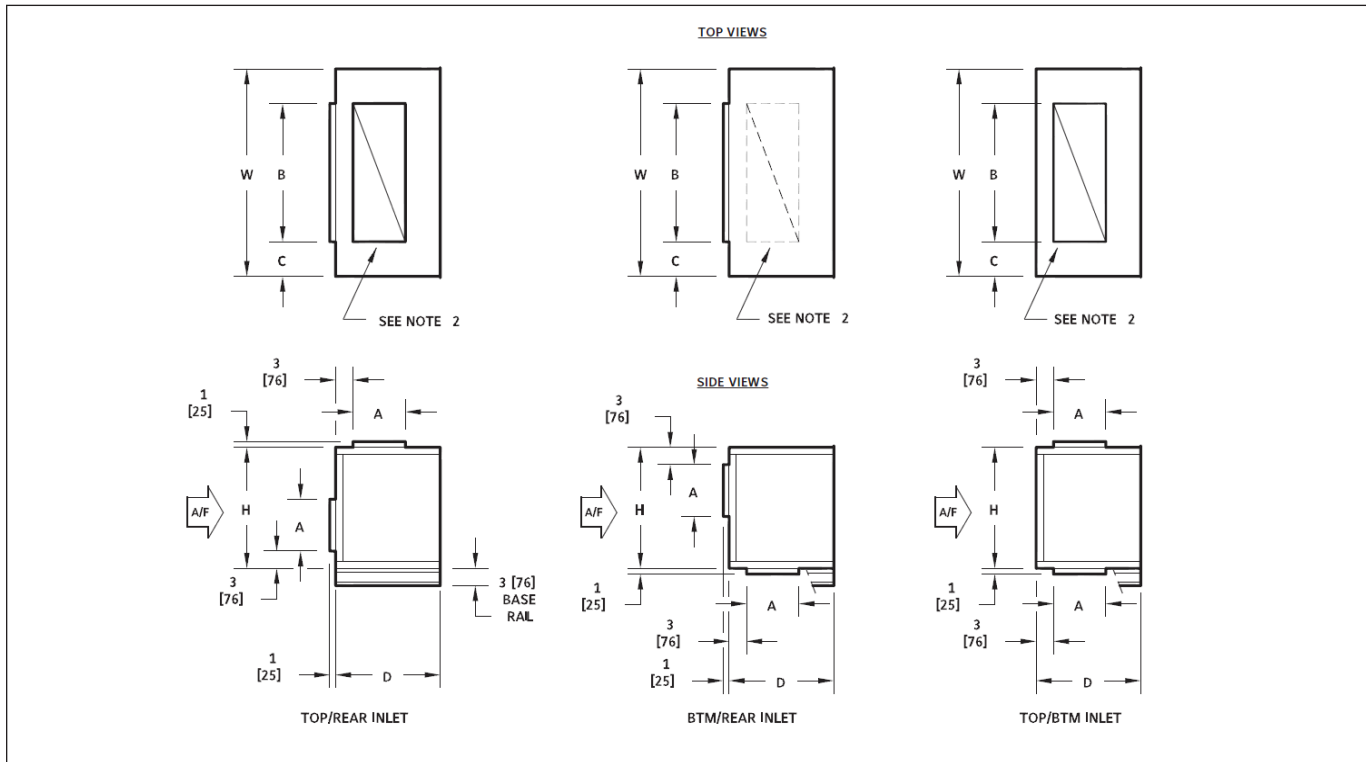

Unit Size	Dimensions					
	H	W	A	B	C	D
08	21" [533]	30" [762]	9" [229]	18" [457]	6" [152]	18" [457]
12	21" [533]	36" [914]	9" [229]	24" [610]	6" [152]	18" [457]
16	21" [533]	44" [1118]	9" [229]	30" [762]	7" [178]	18" [457]
20	21" [533]	50" [1270]	12" [305]	36" [914]	7" [178]	21" [533]
30	30" [762]	59" [1499]	12" [305]	45" [1143]	7" [178]	21" [533]
40	30" [762]	68" [1727]	15" [381]	48" [1219]	10" [254]	24" [610]

General Notes:

1. All dimensions are inches [mm]. All dimensions are +/- 1/4" [6mm]. Metric values are soft conversions.
2. Right-hand unit shown, left-hand unit opposite. Motor/drive location may be specified left-hand or right-hand. Standard-control enclosure location matches motor/drive position.
3. Provide sufficient clearance to permit access to controls and comply with applicable codes and ordinances
4. Flat-Filter rack may be located at unit inlet as required
5. See coil connection detail drawings for coil-connection sizes and location
6. SBV also available with rear-discharge arrangement

Blow-Thru Electric-Heat Notes:

1. Available for horizontal discharge only

Standard Flat-Filter Rack Notes:

1. Standard rack will accept nominal 1" or 2" thick filters
2. 1" duct connections space provided on entering side of rack for connection of field ductwork
3. Hinged-cover provided in both sides of externally mounted filter racks. Internal, standard-filter racks have pivoting bar-type, filter retainer.
4. See individual unit submittal drawings for location of filter rack on unit

Standard Mixing Box Notes:

1. Damper-drive rods are internal, located on both sides of unit
2. Mixing box includes space for standard, flat-filter rack
3. Base rails are included with mixing box

Note: Drawings are not to scale and are not for installation purposes. Contact your Superior Rex representative for more information. All data and dimensions are subject to change without notice.

SBH / SBV Series:: BLOWER-COIL UNIT FEATURES

Standard Features:

Construction

- » Galvanized-steel cabinet construction, 18-gauge minimum
- » 1" thick, fiberglass insulation; mechanically fastened for added security
- » 1" supply-duct collars
- » Gasketed, removable, access panels; sized for easy handling
- » IAQ: Galvanized steel drain pan
- » Left-hand and right-hand arrangement

Coils

- » AHRI Standard 410-certified and labeled
- » ½" O.D. seamless copper tubes
- » Collared and corrugated aluminum fins
- » Manual air-vent plug on all water coils
- » 300 psig working pressure at 200°F
- » Copper sweat connections
- » 0.016" tube wall on water and evaporator coils
- » 0.025" tube wall on steam coils
- » High-efficiency, aluminum-fin surface for optimizing heat transfer, pressure drop, and carryover
- » Mechanically-expanded copper tubes, leak tested to a minimum 450 psig air pressure under water
- » Evaporator coils are factory-sealed and charged with a minimum of 5 psig nitrogen or refrigerated dry air
- » Refrigerant coils are provided with a fixed-orifice distributor
- » Steam coils rated at 15 psig maximum operating pressure at above 35°F

Filter Rack and Filters

- » Hinged side access, flat-filter rack
- » Standard-size, 2" nominal, throwaway filters

Fan Assemblies

- » Forward-curved, double-width, double-inlet (DWDI) fans, statically and dynamically balanced
- » Solid-steel shafting
- » Ball bearings with a minimum design average life (L_{50}) of 100,000 hours

Fan Motor & Drive

- » Open-drip-proof (ODP) motors
- » 1,750 RPM, single-speed, 60 Hz, single-phase motors with inherent thermal protection
- » Three-phase motors
- » Rigid-mount, adjustable motor base
- » Standard cross-section, V-belt drive with 1.2 service factor
- » Adjustable-pitch motor pulley and fixed-pitch blower pulley

Electrical Components

- » Fan motor wired and terminated to junction box
- » cETL listed in compliance with UL/American National Standards Institute (ANSI) Standard 1995

Electric Heat

- » Flanged construction for direct unit mounting, in blow-through configuration
- » Listed for zero-clearance installation
- » Meets NEC requirements
- » Ni-chrome wire in ceramic insulators
- » Stainless-steel element terminals and hardware
- » Element support brackets on maximum 3-½" centers
- » Solid cover with continuous full-height hinge
- » Over-temperature protection
- » Internal wiring rated for 105°C minimum
- » Airflow switch
- » Incoming-line-power distribution block
- » cETL listed in compliance with UL/ANSI Standard 1995
- » Single-point-power connection
- » Heater factory-mounted to unit with cETL listing as an assembly

SBH / SBV Series:: BLOWER-COIL UNIT FEATURES

Optional Features:

Construction

- » Galvanized steel drain pan
- » IAQ stainless steel drain pan
- » External, rubber-in-shear or spring-type, vibration isolators; hangers or floor mount
- » Fan-discharge arrangements
- » Scrim-reinforced, foil-faced insulation meeting American Society for Testing and Materials (ASTM) C1136 for mold, mildew, and humidity resistance
- » Hinged access panels with lift-and-turn fasteners
- » Base rails with rigging slots; factory-assembled and installed
- » Auxiliary (secondary) drain connections

Coils

- » 3, 4, and 6-row chilled-water or R-22 direct-expansion (DX) coils
- » 1 and 2-row hot-water or standard-steam coils
- » Heating coil in preheat or reheat position
- » Coil connections for opposite handing
- » Stainless-steel coil casings
- » 0.025" tube wall on water and evaporator coils
- » Auto air vents on water coils
- » Heat-pump-compatible cooling coils
- » Double-circuit DX coils (intertwined with 50-50 split)
- » 0.025" tube-wall thickness

Filter Rack and Filters

- » 2" pleated filter
- » Spare throwaway or pleated filters
- » High-efficiency filter rack with 2" and 4" filters

Fan Motor and Drive

- » Totally enclosed, fan-cooled (TEFC) motors
- » High-efficiency motors

Inlet-Damper Section

- » Factory-assembled and installed
- » Heavy-gauge, galvanized-steel, formed-blade dampers
- » Low-leak dampers with extruded-vinyl blade seals and flexible-metal jamb seals
- » Parallel-blade operation
- » Interconnecting damper linkage

Electrical Components

- » Motor wiring in conduit
- » Motor starter (contactor with overload for three-phase; contactor for single-phase), factory-installed (mounted and wired)
- » Door-interlocking disconnect switch (non-fused or fused)
- » Hand-off auto (HOA) switch
- » Main fusing
- » Frequency inverters



Superior Rex
605 Shiloh Road
Plano Texas 75074
(ofc): 972.212.4800
(fax): 972.212.4884

SO TOUGH, WE GUARANTEE IT! | www.superiorrex.com